

ARCANE

ALUMINIUM CONSTRUCTIONS
WORKSTATIONS AND CONVEYORS



MODULAR CONSTRUCTION ALUMINIUM PROFILES & ACCESSORIES

ALUMINIUM RANGE

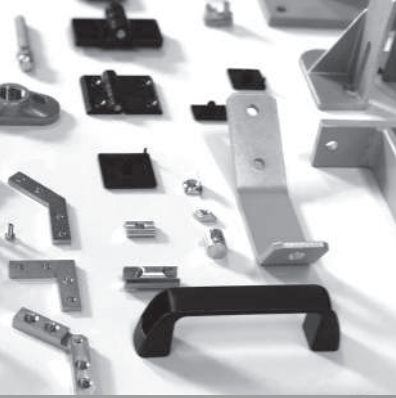
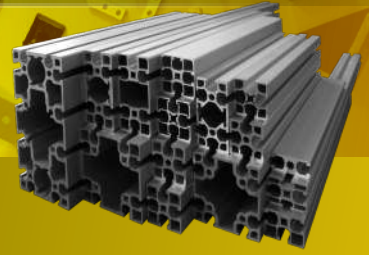

STUDIES AND ASSEMBLED PROJECTS

IN BARS

IN KIT FORM

CUT TO MEASURE



Polycarbonate filler panels,
painted aluminium sheets, gratings, PVC,
wood, glass etc.



MACHINE HOUSING WORKSTATIONS



HOUSINGS Curved housings, counterweight balancing systems, gas springs, gas spring hoods / soundproof peripheral protections etc.



DESKS / WORKSTATIONS

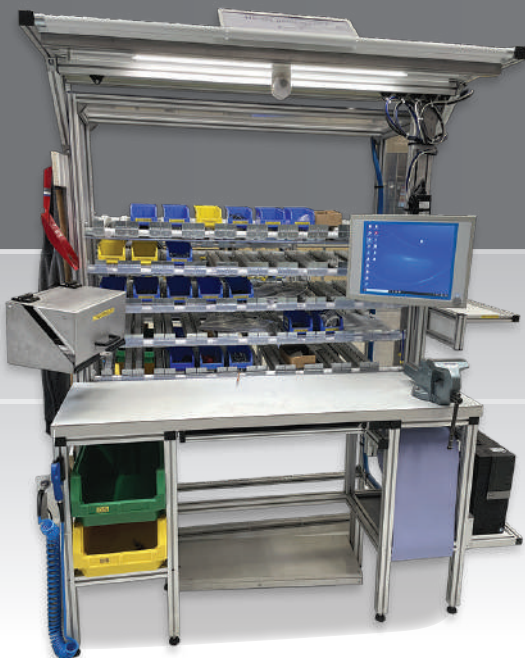

With manual or electrical height adjustment
Ergonomic
Network equipment
Automatic lighting systems

Articulated screen mounts

Integration of motorized and/or gravity conveyors into the station





SIGNALING EQUIPMENT INDICATOR PANELS AND PARTITION WALLS

Screen-printed panels (magnetizable and/or dry wipe etc.)

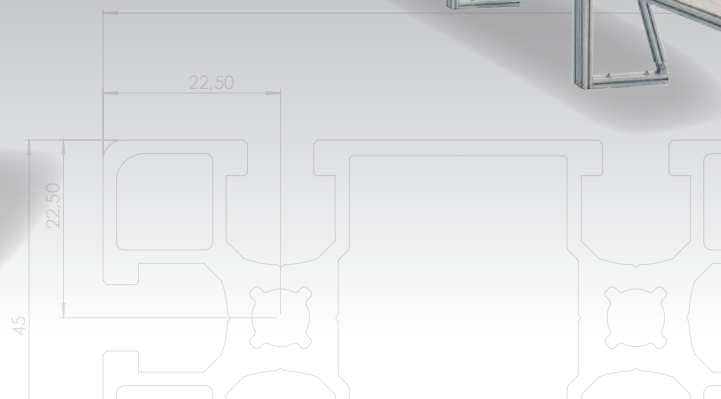
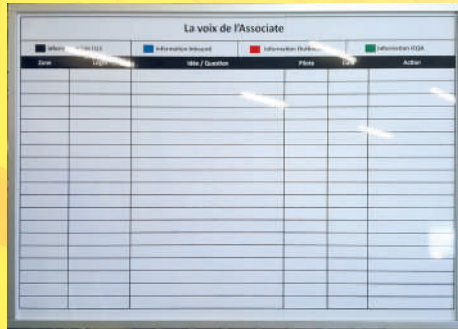
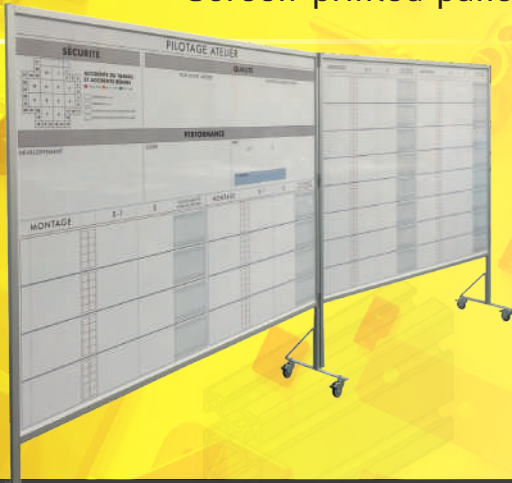



BELT CONVEYORS

Belt conveyors \varnothing 25/52/100 mm

Specifications on request

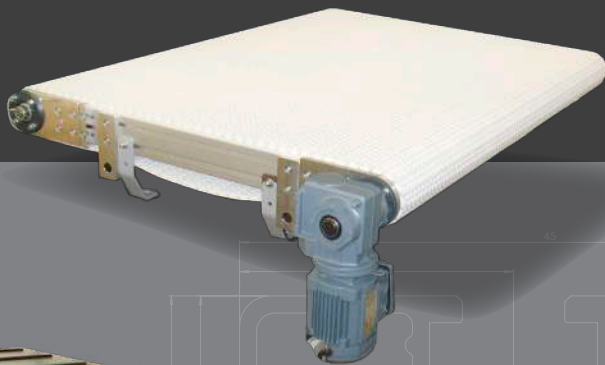
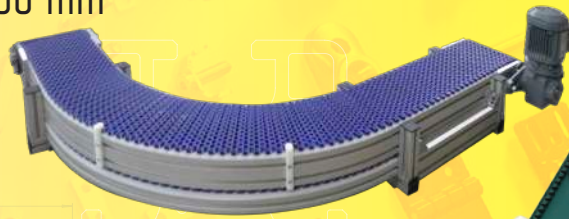
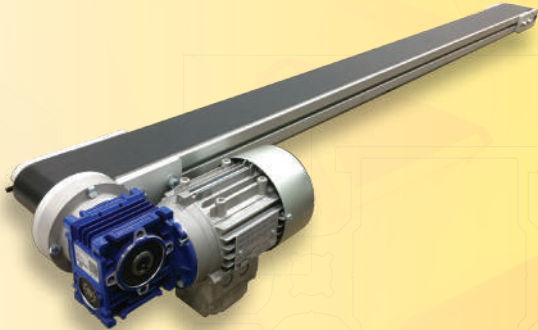

DIRECT DRIVE



SHIFTED DRIVE

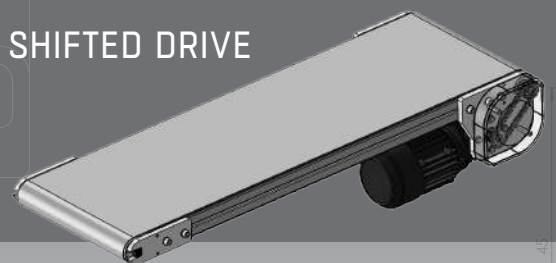

INTERMEDIATE DRIVE

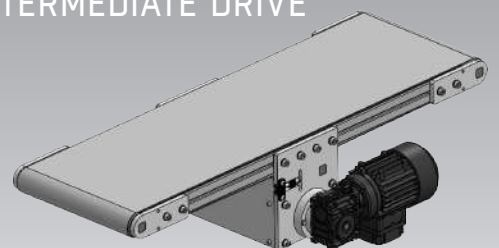



TRC CONVEYORS

TRH CONVEYORS

Roller chain transfers for
light or heavy loads

Ripping systems
with motorized rollers

- Pneumatic separating stops

Rotating tables

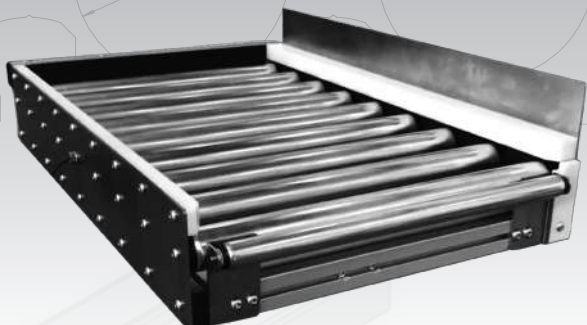
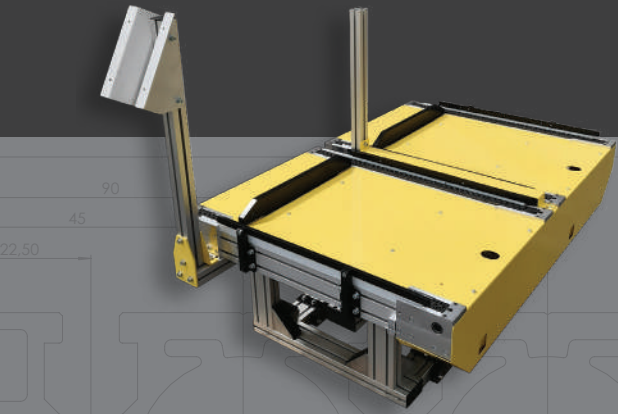
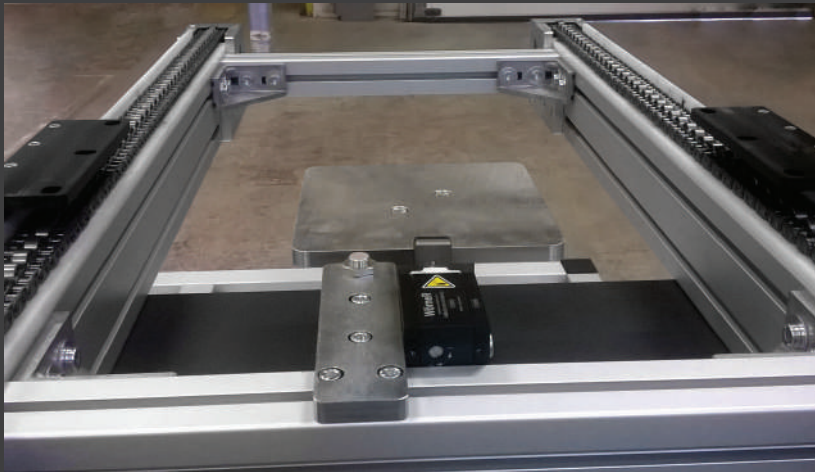
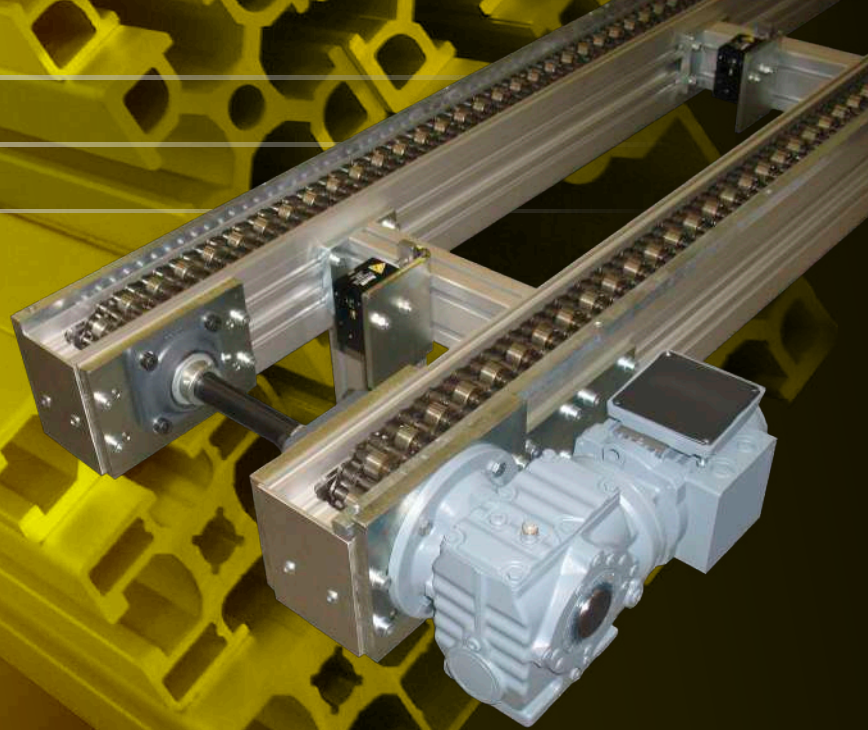

PROFILE SECTIONS



45

SERIES

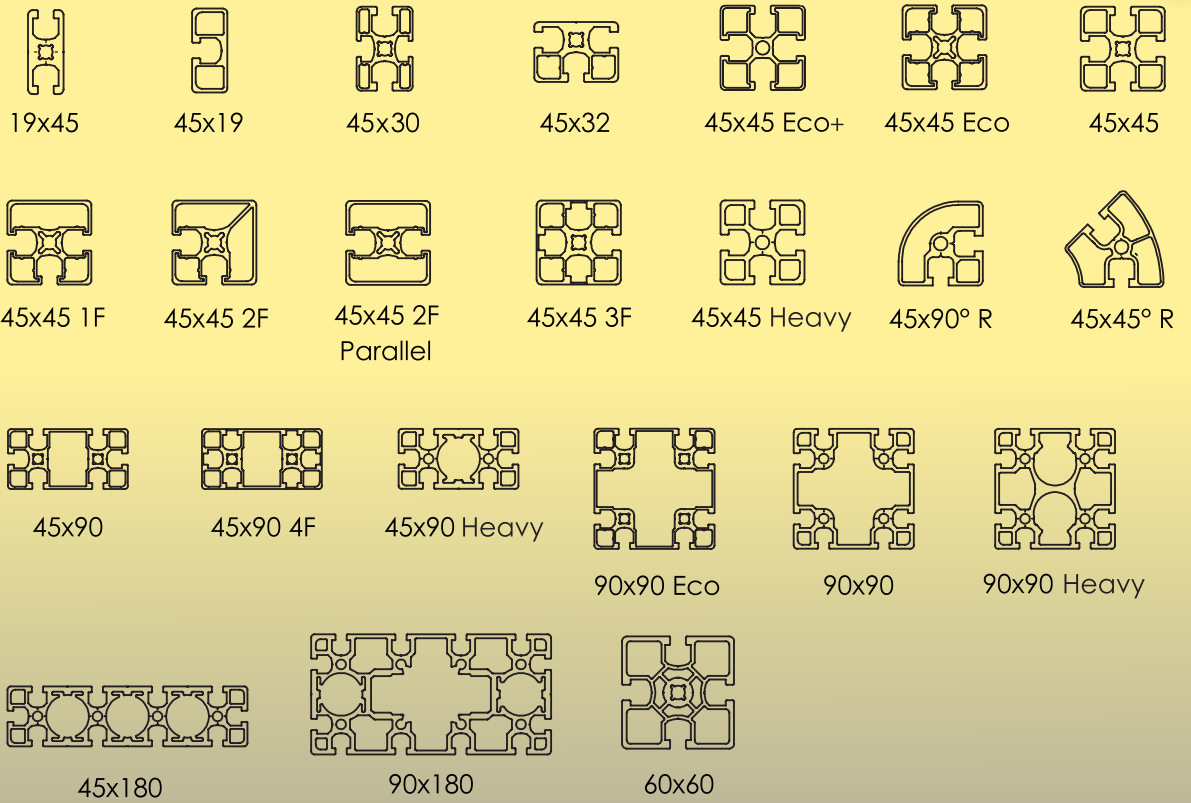

40

SERIES

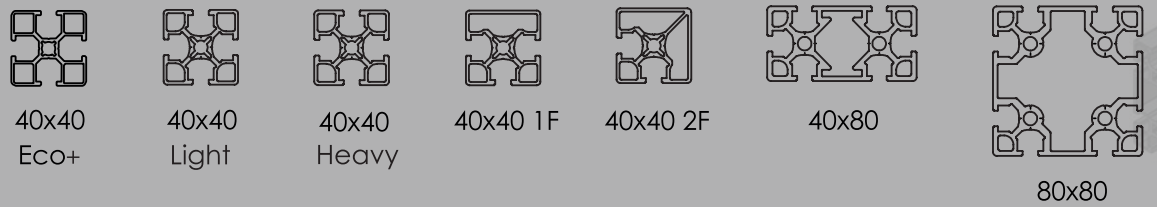

30

SERIES

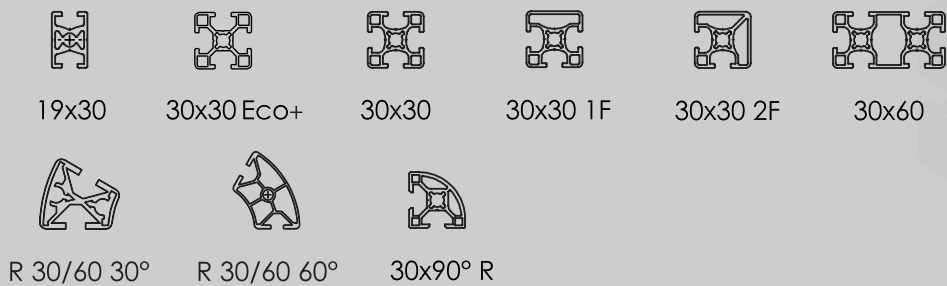

20

SERIES

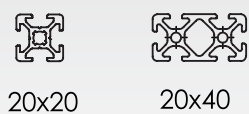



PARIS
NANTES
AIZENAY

ARCANE sas
21 route du Poiré • ZA Le Bois Marie
85190 Aizenay FRANCE

 **+33 (0)2 51 48 38 28**

 **scomm@groupearcane.com**

 **www.arcanefrance.fr**



*notre site web
our website*

